

Copyright. All information furnished within this document, electronic file or design correspondence is the property of Den Hartog Industries, Inc. and shall not be used, disclosed to others or copied without the expressed written consent of Den Hartog Industries, Inc.

LID TRIM AND FASTENING DETAIL

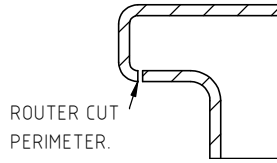

ROUTER CUT PERIMETER.

P.N.10101  
3/8" X 1-1/2" HEX BOLT  
X 12



P.N.11094  
3/8" FLAT WASHER  
X 24

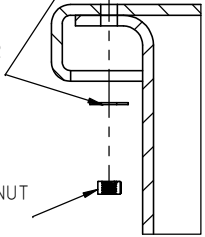

P.N.11093  
3/8" HEX NUT  
X 12

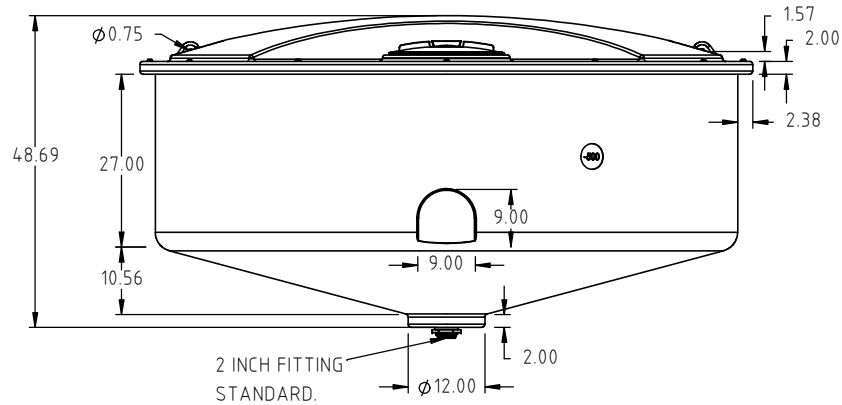
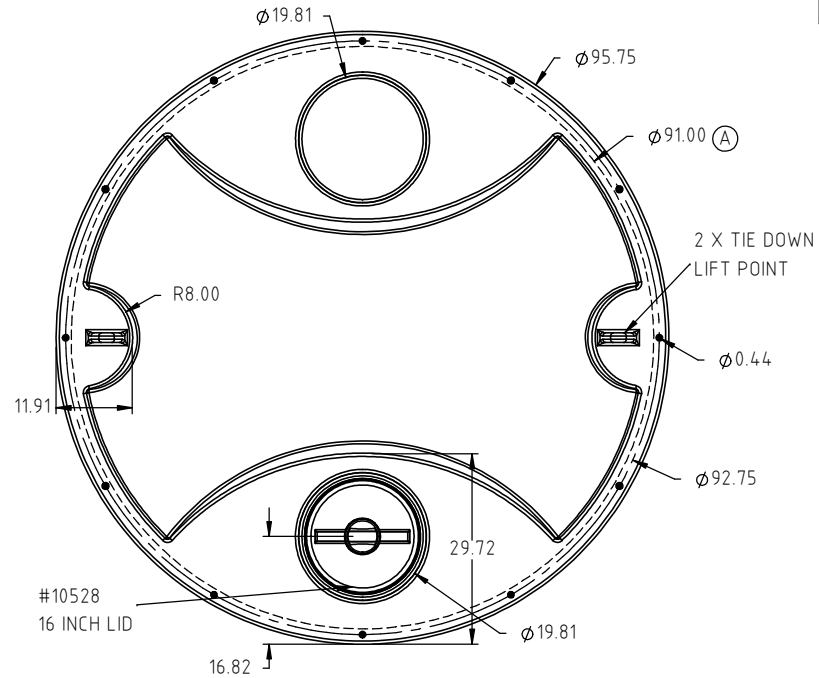

				DRAWN / DATE DHJ 2/3/12	MATERIAL 10420
A	Ø91.00" WAS Ø90.00" ON THE PRINT.	ADH 5/16/17	3385	APPRD. / DATE REH 7/12/12	
REV	DESCRIPTION	BY / DATE	CCN		
ALL DIMENSIONS ARE IN DECIMAL INCHES TOLERANCES UNLESS OTHERWISE SPECIFIED		THIRD ANGLE PROJECTION ANSI 14.5M		SHOT WEIGHT: 212.00 LBS	NOTES: 1.) 0.28" THICK AT FITTING.
POLYETHYLENE		METAL DECIMAL ± .125" FRACTION ± 1/4" ANGLE ± 1°		SHIPPING WEIGHT: 214.00 LBS	
±1% @ 68°F				FINISH:	



**Den Hartog**  
INDUSTRIES, INC.

Acra Roto-Mold Injection Molding Blow Molding Sowjoy

4010 HOSPERS DRIVE S. BOX 425, HOSPERS, IOWA 51238-0425

DESCRIPTION 840 GALLON OPEN CONE WITH BOLT ON TOP	
SCALE N.S.	PART NO. OC0840-90

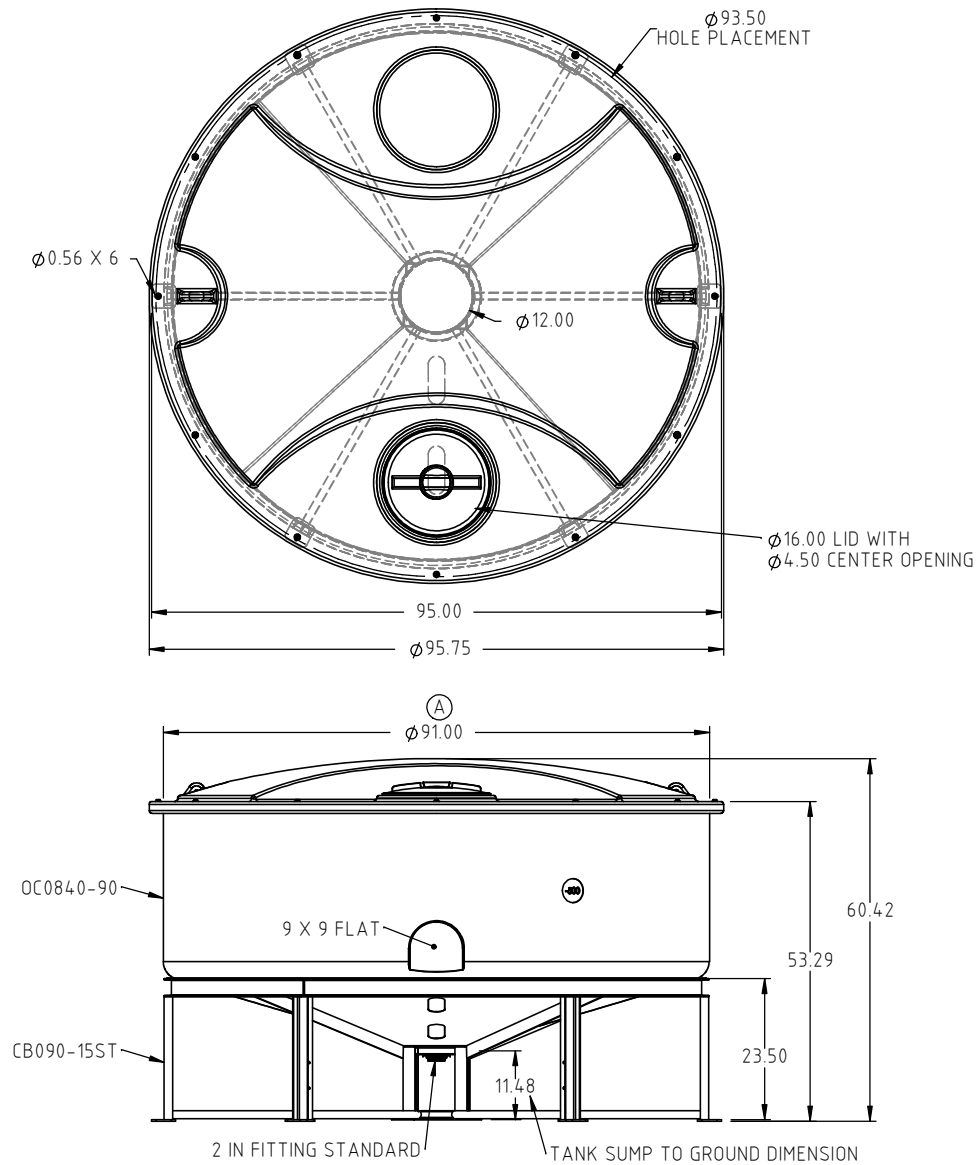

				DRAWN / DATE ADH 4/2/12	MATERIAL SEE TANK AND STAND PRINTS
A	Ø91.00" WAS Ø90.00" ON PRINT.	ADH 5/16/17	3385	APPROD. / DATE REH 7/12/12	
REV	DESCRIPTION	BY / DATE	CCN		
ALL DIMENSIONS ARE IN DECIMAL INCHES TOLERANCES UNLESS OTHERWISE SPECIFIED		THIRD ANGLE PROJECTION ANSI 14.5M		SHOT WEIGHT:	NOTES:
POLYETHYLENE	METAL DECIMAL ± .125" FRACTION ± 1/4" ANGLE ± 1°			SHIPPING WEIGHT: SEE TANK AND STAND PRINTS	
±1% @ 68°F				FINISH:	



**Den Hartog**  
INDUSTRIES, INC.

Acra Roto-Mold Injection Molding Blow Molding Sowjoy

4010 HOSPERS DRIVE S. BOX 425, HOSPERS, IOWA 51238-0425

DESCRIPTION 840 GALLON, 15°, OPEN TOP CONE BOTTOM TANK AND STAND	
SCALE N.S.	PART NO. OC0840-90+CB090-15ST